



SP SERIES LIVE SOUND & INSTALLATION

SP26 - LOUDSPEAKER MANAGEMENT SYSTEM

FEATURES

- High performance 2 in 6 out loudspeaker processor
- High dynamic range
- Convenient front panel controls or remote operation
- Universal mains voltage operation

APPLICATIONS

- Bars And Clubs
- Live Sound Reinforcement
- Ballrooms
- Conference / Speech
- Worship
- Theatres / Performing Arts
- Corporate AV events

DESCRIPTION

The HH Electronics SP26 is a fully featured 2-IN/6-OUT digital speaker management system. Featuring 2 analog inputs and 6 analog outputs, each managed by a powerful DSP Engine. Each input channel provides PEQ, gain control, Dynamic Low boost, noise gate function, RMS compressor, internal White/Pink Noise Generator, and configurable delay. Each output offers up to 7 PEQ and crossover filters.

Easy setup is assured with intuitive front panel controls and an interactive LCD display for local setup, or a dedicated PC control interface for remote monitoring and configuration via USB or RS485.

The SP26 loudspeaker processor is the perfect counterpart to any HH speaker system, suitable in an array of applications, such as live sound, indoor/outdoor events, public address, theatrical performance, and touring. It also comes with expertly created audio presets for use with the TNA line array system, for easy setup straight out of the box.

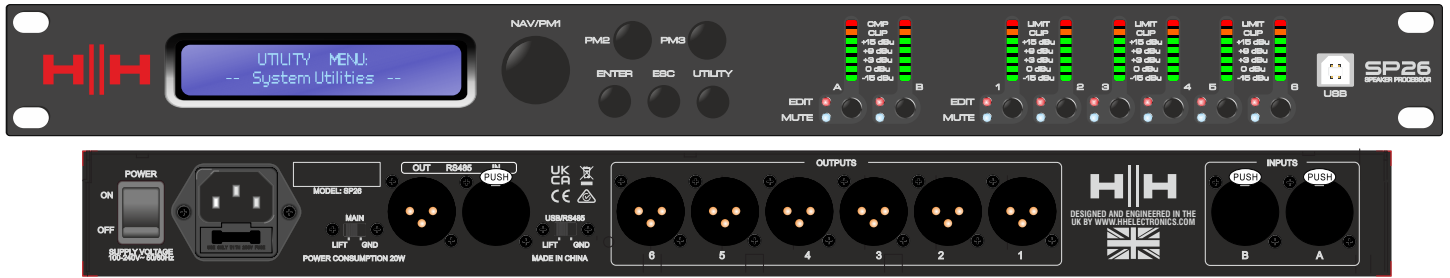

SPECIFICATIONS

Type	Loudspeaker Management System
Audio	
Inputs	Two Electronically Balanced XLR Inputs
Outputs	Six Electronically Balanced XLR Outputs
Minimum Load	150 Ohms
THD%N	0.001% at 1kHz 0dBu
S/N	> 106dB
Frequency Response	20Hz-20kHz; -0.5dB at 20Hz and 20kHz
AD/DA Converters	24bit, 96kHz (48kHz on models pre-October 2023)
General	
Presets	48 user presets (16 pre-loaded TNA examples, may be erased)
Other	Audio Ground Lift switch, USB/RS485 ground lift switch
Remote	RS485 in/out XLR connectors for remote monitoring
DSP	
DSP Engine	DSP, 24bit (data) x 96 bit (coeff.)
DSP Resolution	24bit (data) x 24 bit (coeff.), 54 bit accumulators. 96 bit precision on intermediate processing data
Parametric Equalisation	11 filters per input, 7 filters per output
Filter Type	Bell, Shelving
Filter Gain	From -12dBu up to +12dBu by 0.5dBu resolution steps
Centre Frequency	from 20Hz up to 20kHz with 1Hz resolution steps
Filter Q/BW	Q from 0.4 up to 128
Input Gain	From -12dB to +12dB by 0.1dBu resolution steps;
Output Gain	From -18dB to +12dB by 0.1dBu resolution steps;
Crossover Section HPF/LPF	Butterworth 6/12/18/24/36/48 dB per octave. Bessel 12/24 dB per octave. Linkwitz-Riley 12/24/36/48 dB per octave
Internal Noise Generator	White/ Pink Noise; Level from -30dBu to 0dBu
Input Noise Gate	Threshold from -90dBu up to -60dBu. Attack time from 1ms up to 1000ms; Release time from 10ms up to 1000ms
Input RMS Compressor	Threshold from -14dBu up to +16dBu and Bypass. Ratio 2:1~100:1; Knee: 0% ~ 100%. Attack time from 5ms up to 200ms; Release time from 0.1 sec up to 3 sec
Output RMS Compressor	Threshold from -14dBu up to +16dBu and Bypass. Ratio 2:1~100:1; Knee: 0% ~ 100%. Attack time from 5ms up to 200ms; Release time from 0.1 sec up to 3 sec
Output Peak Limiter	Threshold from -14dBu up to +16dBu and Bypass. Attack time from 5ms up to 200ms; Release time from 0.1 sec up to 3 sec.
Dynamic Loudness Filter	Input: Boost Filter from 0% to 100%; Frequency from 20Hz to 20kHz. Output (Only for output 1,3,5): Attenuation Filter from 0dBu to -6dBu; Frequency. 20Hz to 1kHz Q from 1 to 9.9 step 0.1
Delay	900 ms 10.4us increment/decrement steps per input channel. 340 ms 10.4us increment/decrement steps per output channel
Residual Noise	< -90dBu
Power Requirements	
AC Power	Universal voltage 100V-240V~ 50/60Hz, three pin IEC socket
AC Power Consumption	<30W
Sizes	
Unit dimensions (HWD)	44 x 483 x 229mm, 1.7" x 19" x 9"
Unit weight	3.5Kg, 7.7 lbs
Carton dimensions (HWD)	9 x 53 x 30CM, 3.5" x 20.9" x 11.8" , 0.014 M3
Packed weight	4.5Kg, 9.9 lbs
EAN	5060109457957



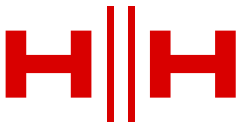

SP26 - LOUDSPEAKER MANAGEMENT SYSTEM

DIMENSIONS

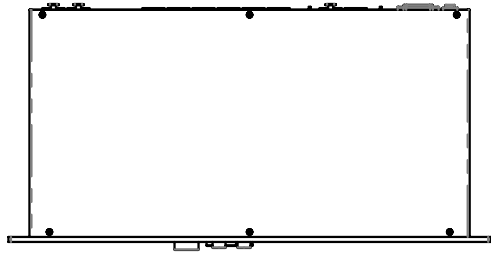
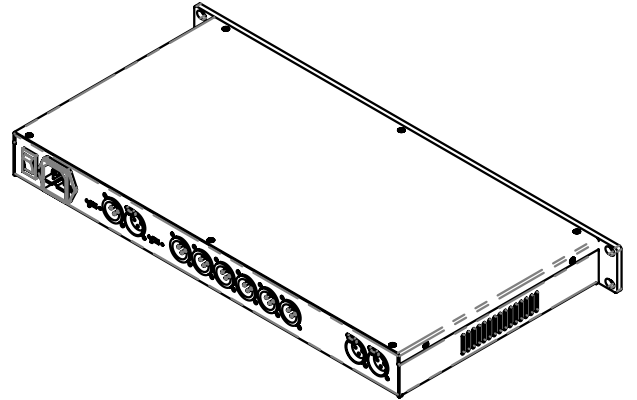
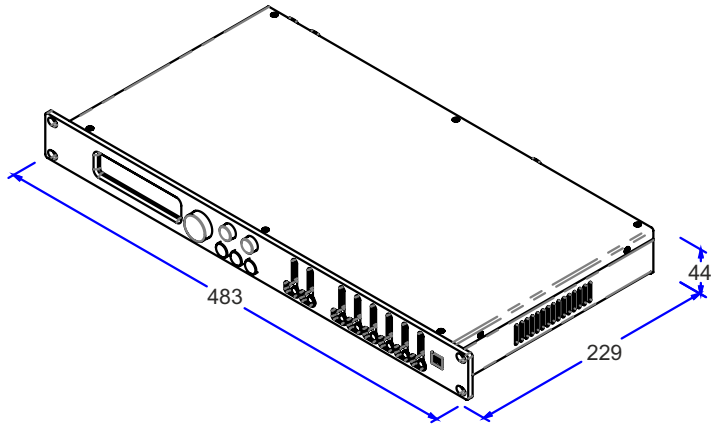

TOP

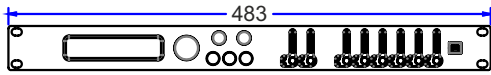

FRONT

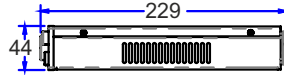

RIGHT



REAR